



RDD810KN/NF

Touch Screen Flush-mount Room Thermostats with KNX Communications

For heating applications

- KNX bus communications (S-Mode and LTE-Mode)
- Large display with backlight
- 2-position (ON/OFF) control with potential free output for heating
- 2 multifunctional inputs for keycard, window contact, external temperature sensor, presence detection, and etc.
- Operating modes: Comfort, Economy and Protection
- Minimum and maximum limitation of room temperature setpoint
- Control depending on the room or external temperature sensor
- Adjustable commissioning and control parameters
- Commissioning with Synco ACS, ETS4 or via local HMI
- Interoperation into Synco 700
- Integration into Desigo via group (ETS4) or via individual addressing
- Integration into third-party system via group addressing (ETS4)
- AC 230 V operating voltage
- RDD810KN/NF: Mounting on recessed square 86 mm box with 60.3 mm fixing centers and min 40 mm depth, requires additional mounting frame

Room temperature control in a heating system:

Typical applications:

- Apartments
- Commercial buildings
- Schools

For the control of the following pieces of equipment:

- Thermal valves or zone valves
- Gas or oil boilers
- Fans
- Pumps
- Floor Heating

The heating unit can be configured using one of the following tools via remote configuration:

- Local HMI
- Synco ACS
- ETS4

Functions

- Room temperature control via built-in temperature sensor or external room temperature sensor.
- Selection of operating mode via touch screen.
- Temporary Comfort mode extension.
- Display of current room temperature or setpoint in °C and/or °F.
- Minimum and maximum limitation of room temperature setpoint.
- Key lock function: unlock, total lock and setpoint
- 2 multifunctional inputs, freely selectable for:
 - Window contact
 - Presence detector
 - External room temperature or return air temperature sensor
 - Fault input
 - Monitor input for temperature sensor or switch state
- Floor heating temperature limitation.
- Reload factory settings for commissioning and control parameters.
- Wizard function for easy commissioning via HMI
- KNX bus (terminals CE+ and CE-) for communication with Synco 700 or KNX compatible devices
- Display of time of day via KNX bus
- Display of outdoor temperature via KNX bus on INFO page
- Time scheduling and central control of setpoints via KNX bus
- With a Synco RMx7xx controller, the energy demand signal of the thermostat is used to optimize energy supply.

Applications

The thermostat supports the heating applications:

- Hydronic floor heating controls
- Radiators
- Wall-hung boilers

Application Examples

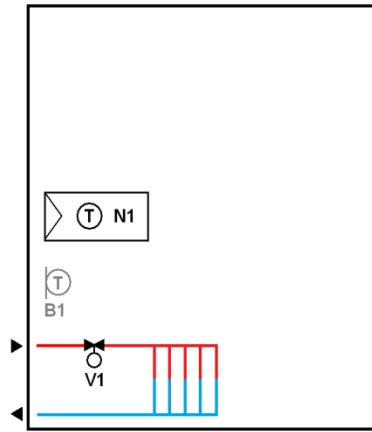

Room thermostat to control the valve of the radiator application

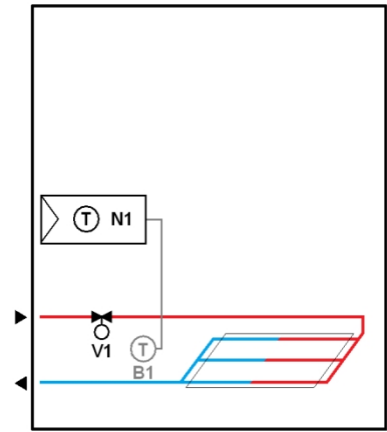

Room thermostat to control the valve for the floor heating application

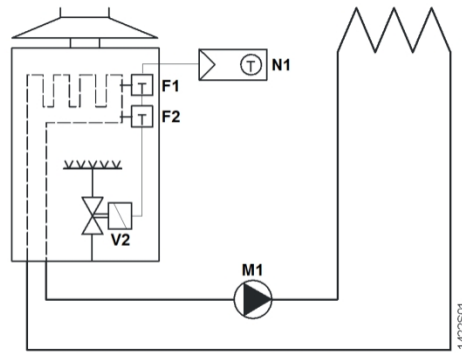

Room thermostat with direct control of a gas-fired wall-hung boiler

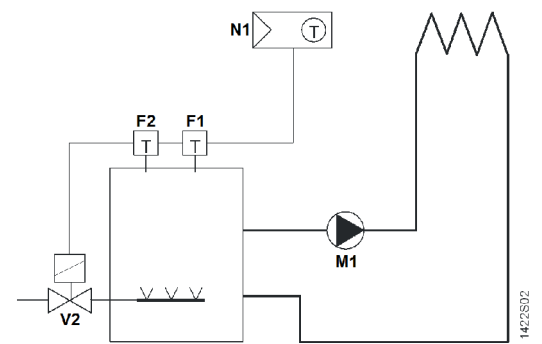

Room thermostat with direct control of a gas-fired floor-standing boiler

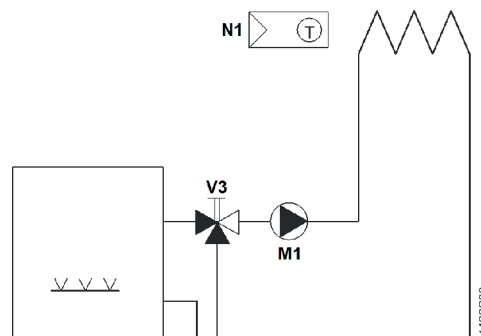

Room thermostat with direct control of a heat pump (pre-controlled by manual mixing valve)

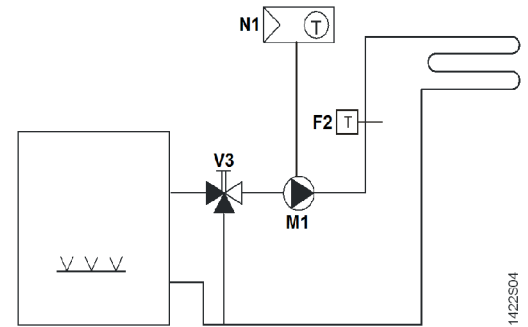

Room thermostat with direct control of hydronic floor heating system

F1 Thermal reset limit thermostat
 F2 Safety limit thermostat
 M1 Circulating pump

N1 Room thermostat
 V1 2-port valve
 V2 Mixing 3-port valve with manual adjustment
 V3 Magnetic valve

Type summary

Product no.	Stock no.	Operating voltage	Control outputs			Suitable for
			3-pos	ON/OFF	DC 0..10 V	
RDD810KN/NF ²⁾	S55770-T336	AC 230 V	--	2 ¹⁾	--	Square conduit box ²⁾

¹⁾ ON/OFF output with potential free input from AC 24...230 V













²⁾ Mounting frames are not included and must be ordered separately. See "Accessories"

Ordering

- When ordering, indicate product number, SSN and name.
For example: **RDD810KN/NF (S55770-T336) room thermostat**
- A mounting frame must be ordered for RDD810KN/NF installation (See "Accessories")
- Order valve actuators separately.

Equipment combinations

ON/OFF actuators

Type of unit		Product no.	Data sheet
Cable temperature sensor or changeover sensor cable length 2.5 m NTC (3 kΩ at 25 °C)		QAH11.1 ^{d)}	1840
Room temperature sensor NTC (3 kΩ at 25 °C)		QAA32	1747
Cable temperature sensor, cable length 4 m NTC (3 kΩ at 25 °C)		QAP1030/UFH	1854
Electromotoric ON/OFF actuator		SFA21...	4863
Electromotoric ON/OFF valve and actuator ^{a)}		MVI.../MXI...	A6V11251892
Zone valve actuators ^{a)}		SUA...	4832
Thermal actuator ^{b)}		STA23...	4884
Thermal actuator ^{c)}		STP23...	4884
Damper actuator		GDB..	4634
Damper actuator		GSD..	4603
Damper actuator		GQD..	4604
Rotary damper actuator		GXD..	4622

^{a)} only available in AP, UAE, SA and IN

^{b)} for radiator valve

^{c)} for small valves 2.5 mm

d) both QAH11.1 and QAP1030/UFH are for floor heating applications, such as temperature limitation controls. QAP1030/UFH has a special head and 4 m long that is more suitable for such application

Note: Refer to data sheets of the actuators for the maximum number of parallel operation.

Accessories

Designation	Product no. / SSN	Data sheet
Conduit box for RDD810KN/NF 	ARG71 / S55770-T137	N3009
Single mounting frame ^{*)} , Ivory White	ARG800.1 / S55770-T370	--
KNX Power supply 160 mA (Siemens BT LV)	5WG1 125-1AB02	--
KNX Power supply 320 mA (Siemens BT LV)	5WG1 125-1AB12	--
KNX Power supply 640 mA (Siemens BT LV)	5WG1 125-1AB22	--

^{*)} See the dimensions of mounting frame on page 14.

Mechanical design

The thermostats consist of the following parts:

- Front panel with electronics, operating elements and built-in room temperature sensor.
- Mounting base with power electronics.
- Mounting frame is an additional part to complete the installation for RDD810KN/NF.

The rear of the mounting base contains the screw terminals. Slide the front panel in the mounting base and snap on.

Operation and settings

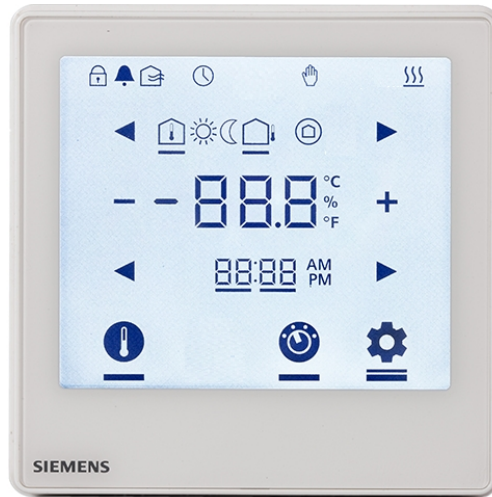

Display

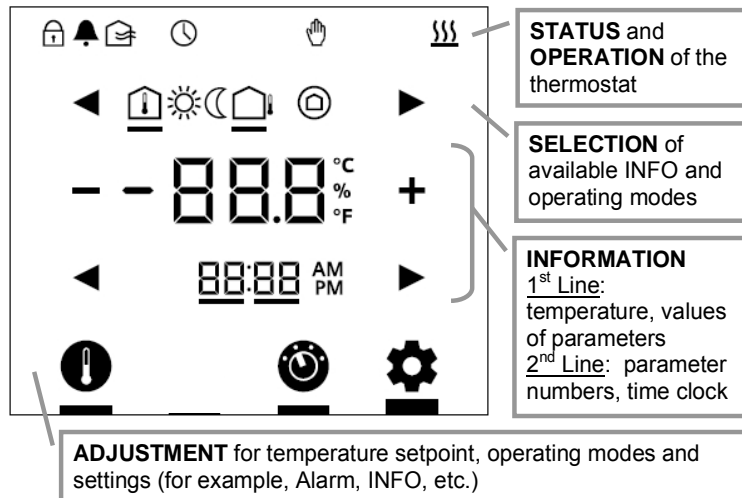

Status symbols:			
	Key lock		Manual override
	Alarm / Service reminder		Heating active
	Scheduler via bus		
Selection symbols:			
	Indoor temperature		Comfort mode
	Outdoor temperature		Economy mode
			Protection mode

Operational icons:	
	Increment, decrement OR selection
	Selection OR move to next items
	Temperature OR parameter values, and etc.
	Time clock (12 / 24 hour), parameter number OR password, and etc.
	Setpoint mode (temperature only)
	Operating mode
	Setting mode

See the "Reference documentation", page 12, for information on how to engineer the KNX bus (topology, bus repeaters, etc.) and how to select and dimension connecting cables for supply voltage and field devices.

Mounting and installation

Mount the room thermostat on a conduit box. Do not mount on a wall in niches or between bookshelves, behind curtains, above or near heat sources, or exposed to direct solar radiation. Mount about 1.5 m above the floor.

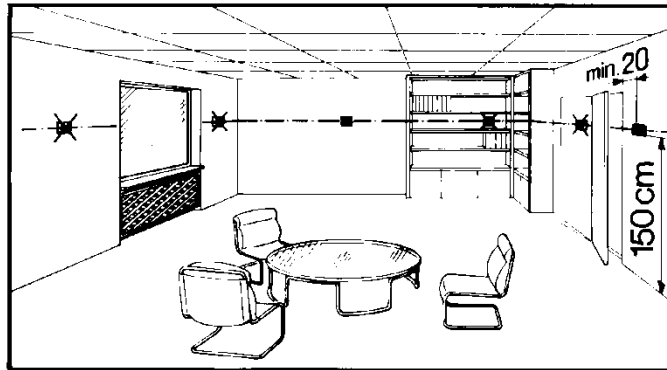

Mounting / Dismounting



- Do not apply excessive force on screws! The deformation of the mounting frame may lead to improper connections and operation of the unit.
- Mount the room thermostat on a clean, dry indoor place without direct airflow from a heating / cooling device, and not exposed to drips or water.
- Before removing the front cover, disconnect the power supply.

Wiring



See the User Manual for the installation instructions enclosed with the thermostat.

- Comply with local regulations to wire, protection and earth the thermostat.
- The device has no internal fuse for supply lines to fan and actuators. To avoid risk of fire and injury due to short-circuits, the AC 230 V mains supply line must have a circuit breaker with a rated current of no more than 10 A.
- The wiring cross section used for power supply (L, N) and 230 V outputs (Qxx - N) must be adapted to the preceding overload protection elements (max 10 A) under all circumstances. Comply under all circumstances with local regulations.
- Properly size the cables to the thermostat and valve actuators for AC 230 V mains voltage.
- Cables of SELV inputs X1-M / X2-M: Use cables with min 230 V insulation, as the conduit box carries AC 230 V mains voltage.
- Inputs X1-M or X2-M of different units (e.g. window contact) may be connected in parallel with an external switch. Consider overall maximum contact sensing current for switch rating.
- KNX communication cables (input CE+ / CE-): Use cables with min 230 V insulation, as the conduit box carries AC 230 V mains voltage.
- When a KNX bus power supply is connected on the line with communicating thermostats and Synco controllers, the internal KNX power supply of the Synco controllers must be switched off.
- No cables provided with a metal shield.
- Disconnect from supply before opening the cover.

Commissioning notes

Before power up

No DIP switch setting is required for RDD810KN... thermostats.

Wizard function

After power up, the wizard function guides users to configure the basic parameters for normal operation according to the table below.

Touch ◀ / ▶ to advance / return to any parameter;

Touch + / - to change value.

LCD display	Parameter	Range	Factory setting
	User operating mode profile	1: comfort > protection 2: comfort > economy > protection	1
	Selection of °C or °F	0: °C 1: °F	0
	Standard display	0: Room temperature 1: Setpoint	0
	Display info line (2 nd line of LCD display)	0: --- (No display) 3: Time of day (12h) via bus 4: Time of day (24h) via bus	0
	Functionality of X1	0: --- No function 1: Ext / Return Temp (AI) 3: Window open detect (DI) 6: Fault input (DI) 7: Monitor input (Digital)	3
	Functionality of X2	8: Monitor input (Temp) 10: Presence detection (DI)	1
	Operating action of X1	Normal Open (NO) Normal Close (NC)	Normal Open (NO)
	Operating action of X2		
	-	End of wizard	-

If more details are required about parameters, refer to basic documentation P3174.

Reset

To reload factory setting for all parameters, set parameter P71 to **ON**. Restart the thermostat after reset, all LCD segments flash, indicating that the reset is correct. 3 seconds later, the thermostat is ready for commissioning by qualified HVAC staff.

Applications

RDD810KN... thermostats are for heating applications. Configure or changing parameter settings during commissioning using one of the following tools:

- Local HMI
- Synco ACS
- ETS4

Connect tool

Connect the Synco ACS or ETS4 tools to the KNX bus cable at any point for commissioning:

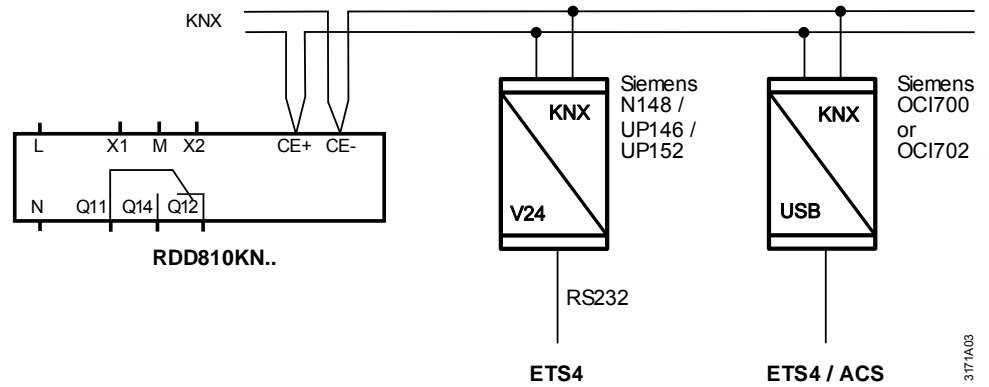

ACS and ETS4 require an interface:

- RS232 KNX interface (such as Siemens N148 / UP146 / UP152)
- OCI700 USB-KNX interface

Note: An external KNX bus power supply is required if an RDD810KN/NF is connected directly to a tool (ACS or ETS4) via KNX interface.

Control parameters	<p>The thermostat's control parameters can be set to ensure optimum performance of the entire system (refer to basic documentation P3174).</p> <p>The parameters can be adjusted using</p> <ul style="list-style-type: none"> – Local HMI – Synco ACS – ETS4 <p>For commissioning via local HMI, refer to user manual B3174... for setting the passwords.</p>
Control sequence	<ul style="list-style-type: none"> • Only heating sequence is available.
Calibrate sensor	<ul style="list-style-type: none"> • Recalibrate the temperature sensor if the room temperature displayed on the thermostat does not match the room temperature measured (after min. 1 hour of operation). To do this, change parameter P05.
Setpoint and range limitation	<ul style="list-style-type: none"> • We recommend to review heating setpoint and their range limitation via parameters P08...P11. If necessary, adjust them to achieve maximum comfort and save energy.
Programming mode	<p>The programming mode helps identify the thermostat in the KNX network during commissioning.</p> <p>Touch and hold  for more than 5 seconds to activate programming mode, which is indicated on the display with Pr09. Programming mode remains active until thermostat identification is complete.</p>
Assign KNX device address	<p>Assign device address (P81) via HMI, ACS or ETS4.</p> <p>With device address set to 255, the communication is deactivated (no exchange of process data).</p>
Assign KNX group addresses	<p>Use ETS4 to assign the KNX group addresses of the RDD communication objects.</p>
KNX serial number	<p>Each device has a unique KNX serial number inside the front panel. An additional sticker with the same KNX serial number is enclosed in the packaging box. This sticker is intended for installers for documentation purposes.</p>

Disposal



- The device is considered electrical and electronic equipment for disposal in terms of the applicable European Directive and may not be disposed of as domestic garbage.
- Dispose of the device through channels provided for this purpose.
 - Comply with all local and currently applicable laws and regulations.

Technical data

⚠ Power supply	Rated voltage	AC 230 V
	Overvoltage category	III
	Frequency	50/60 Hz
	Power consumption	Max. 6.0 VA / 2.1 W
Caution ⚠	No internal fuse. External preliminary protection with max C 10 A circuit breaker required in all cases.	
	<hr/>	
Outputs	Control output Q11, Q12, Q14 (SPDT)	AC 24...230 V
	Rating Min, Max resistive (inductive)	Min. 10 mA, Max. 5(2) A
Caution ⚠	No internal fuse. External preliminary protection with max C 10 A circuit breakers in the supply line (Q11) required in all cases.	
	<hr/>	
Inputs	Multifunctional input X1-M/X2-M	
	Temperature sensor input:	
	Type	See "Equipment combinations"
	Temperature range	0...49 °C
	Cable length	Max. 80 m
	Digital input:	
	Operating action	Selectable (NO / NC)
	Contact sensing	SELV DC 0...5 V / Max. 5 mA
	Parallel connection of several thermostats for one switch	Max. 20 thermostats per switch
	Insulation against mains voltage (SELV)	4 kV, reinforced insulation
Function of inputs:		Selectable
External temperature sensor, window contact,	X1: P38	
presence detection, fault contact, monitoring input	X2: P40	
<hr/>		
KNX bus	Interface type	KNX, TP1-64 (electrically isolated)
	Bus current	5 mA
	Bus topology: See KNX manual (Reference documentation, see below)	
<hr/>		
Operational data	Switching differential, adjustable	
	Heating mode	(P30) 2 K (0.5...6K)
	Setpoint setting and range	
	☀ Comfort	(P08) 21 °C (5...40 °C)
	☾ Economy	(P11) 15 °C (OFF, 5...40 °C)
	🔌 Protection	(P65) 8 °C (OFF, 5...40 °C)
	Multifunctional input X1/X2	
	Input X1 default value	(P38) 3 (Window contact)
	Input X2 default value	(P40) 1 (External temperature sensor)
	Built-in room temperature sensor	
	Measuring range	0...49 °C
	Accuracy at 25 °C	< ± 0.5 K
	Temperature calibration range	± 3.0 K
	Settings and display resolution	
Setpoints	0.5 °C	
Current temperature value displayed	0.5 °C	

Environmental conditions	Storage	As per IEC 60721-3-1
	Climatic conditions	Class 1K3
	Transport	As per IEC 60721-3-2
	Climatic conditions	Class 2K3
Standards and directives	Operation	As per IEC 60721-3-3
	Climatic conditions	Class 3K5 ¹⁾
	EU Conformity (CE)	8000078258_xx ^{*)}
	Electronic control type	2.B (micro-disconnection on operation)
Environmental compatibility	 RCM conformity to EMC emission standard	AS/NZS 61000-6-3
	Safety class	II as per EN 60730
	Pollution class	Normal
	Degree of protection of housing	IP 30 as per EN 60529
	The product environmental declaration E3174en contains data on environmentally compatible product design and assessments (RoHS compliance, materials composition, packaging, environmental benefit, disposal).	
	Based on EU Regulation 813/2013 (Eco design directive) and 811/2013 (Labelling directive) concerning space heaters, combination heaters, the following class apply:	
Eco design and labelling directives	- Application with On/Off operation of a heater	Class I value 1%
	General	
General	Connection terminals	Solid wires or prepared stranded wires 1 x 0.4...1.5 mm ² or 2 x for KNX cables/sensor
	Minimal wiring cross section on L, N, Qxx	Min 1.5 mm ²
	Housing front color	Ivory White
	Weight without / with packaging	0.145 kg / 0.245 kg
^{*)} The documents can be downloaded from http://siemens.com/bt/download . ¹⁾ No condensation is allowed.		
Reference documentation	Handbook for Home and Building Control - Basic Principles (http://www.knx.org/knx-en/training/books-documentation/knx-association-books/index.php)	
	Synco CE1P3127 Communication via the KNX bus for Synco 700, 900 and RXB/RXL Basic documentation	
Desigo	CM1Y9775 Desigo RXB integration – S-mode	
	CM1Y9776 Desigo RXB / RXL integration – individual addressing	
	CM1Y9777 Third-party integration	
	CM1Y9778 Synco integration	
	CM1Y9779 Working with ETS	

Connection terminals

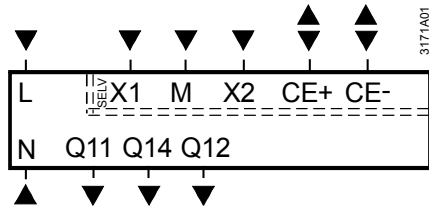

L, N	Operating voltage AC 230 V
Q11, Q12	NC contact (for NO valves)
Q11, Q14	NO contact (for NC valves)
X1, X2	Multifunctional input for temperature sensor or potential-free switch
	Factory setting:
	– X1 = Window contact
	– X2 = External sensor
	(function can be selected via parameter P38 / P40)
M	Measuring neutral for sensor and switch
CE+	KNX data +
CE-	KNX data -

Connection diagrams

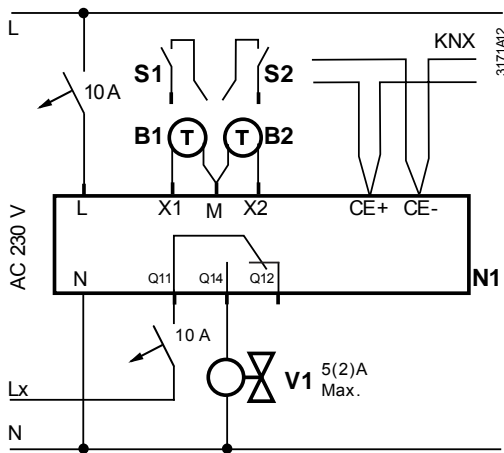

N1	Room thermostat
V1	Valve actuator
Lx	AC 24...230 V
S1, S2	Switch (keycard, window contact, presence detector, etc.)
B1, B2	Temperature sensor (return air temperature, external room temperature, changeover sensor, etc.)
CE+	KNX data +
CE-	KNX data -

Dimensions (mm)

RDD810KN/NF
for square conduit
boxes only

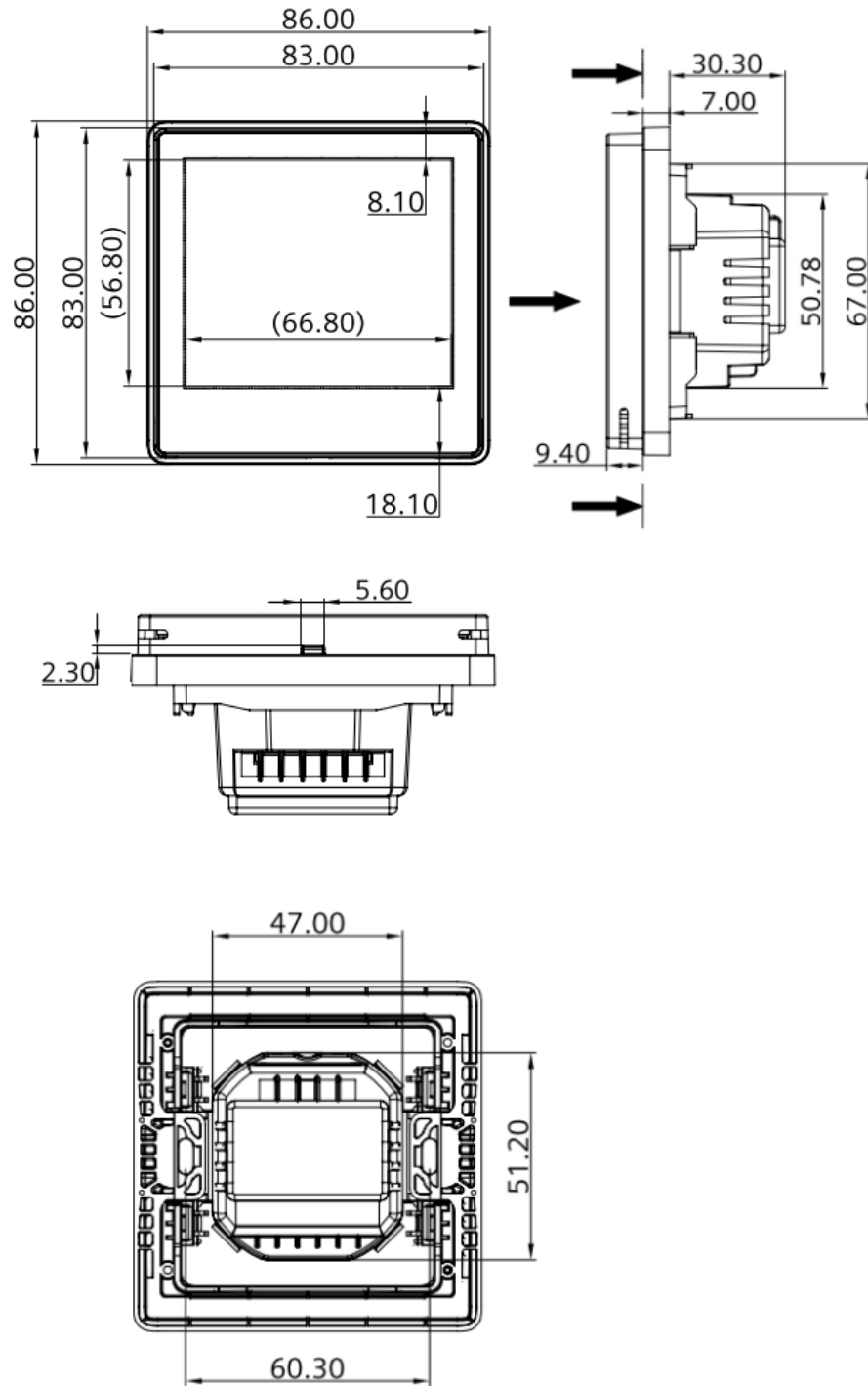

ARG800.1 single
mounting frame for
RDD810KN/NF

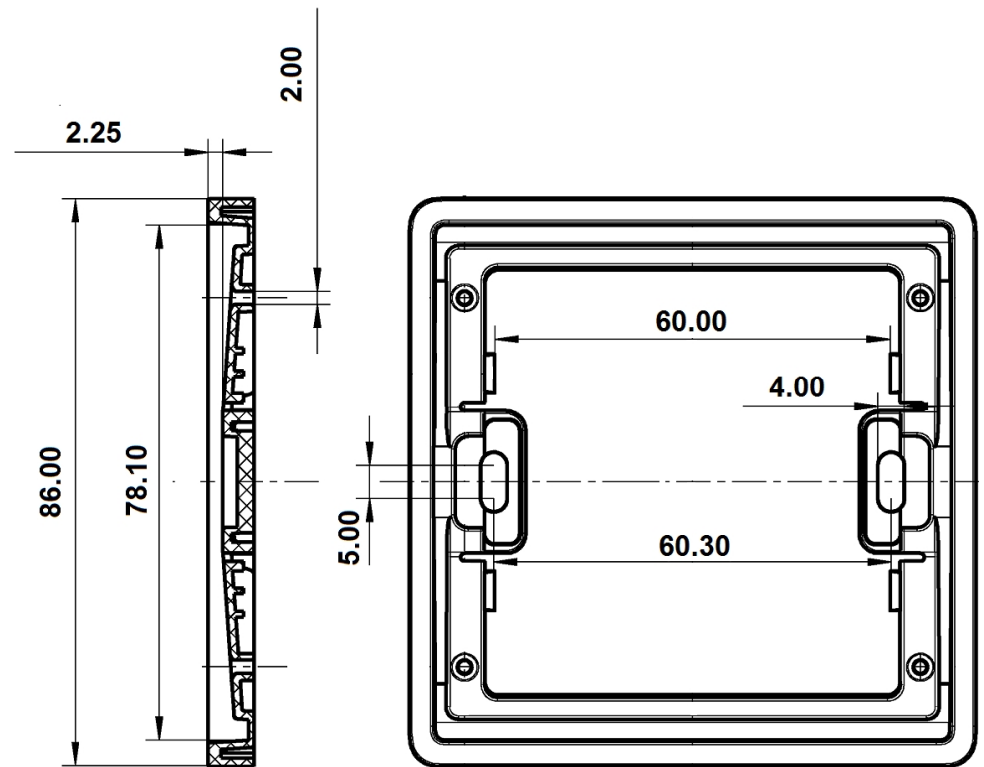

Issued by
Siemens Switzerland Ltd.
Building Technologies Division
International Headquarters
Theilerstrasse 1a
CH-6300 Zug
Tel. +41 58 724 2424
www.siemens.com/buildingtechnologies

© Siemens Switzerland Ltd, 2016 - 2018
Technical specifications and availability subject to change without notice.